





HUGO WHITE

design by Slamp Creative Department

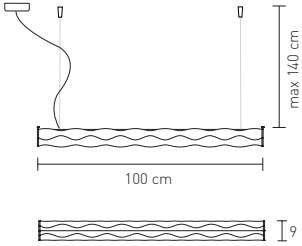

New Collections January 2017 page 18

PRODUCT	SIZE	COLOUR	CODE
<p>SUSPENSION</p> <p>LED: 30W - 220V - 3000 Lumen 2700 Kelvin - Dimmable</p> <p>Made of: Lentiflex®</p> <p>Weight: net Kg 1,20 - gross Kg 1,65</p> <p>Package: 14 x 14 x h113cm</p> <p>CE IP 20  </p>		<p> WHITE</p>	<p>HUG89SOS0000WT000</p>

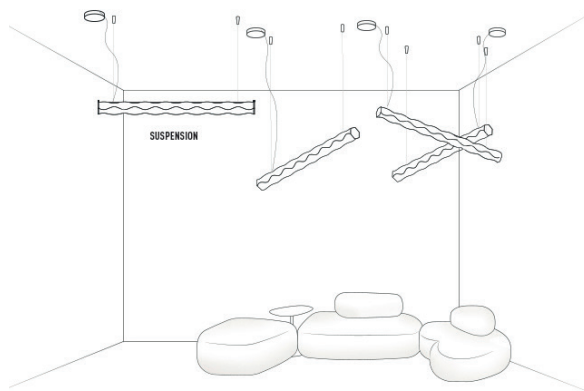
HUGO ENTIRE COLLECTION



ENERGY CLASS

 This luminaire contains built-in LED lamps. LED 

The lamp cannot be changed in the luminaire.

SLAMP: HUGO WHITE 874/2012

A++

A+

A

~~B~~

~~C~~

~~D~~

~~E~~

}

